

BITTE VOR DER MONTAGE BEACHTEN !

Montageanleitung 0246/15

- Packen Sie bitte alle Montageteile aus, vergleichen Sie diese mit der u.s. Liste der Montageteile und prüfen Sie, ob alle Teile aus der Liste vorhanden sind.
- Bitte keine Teile entsorgen, bevor die Montage komplett abgeschlossen wurde.

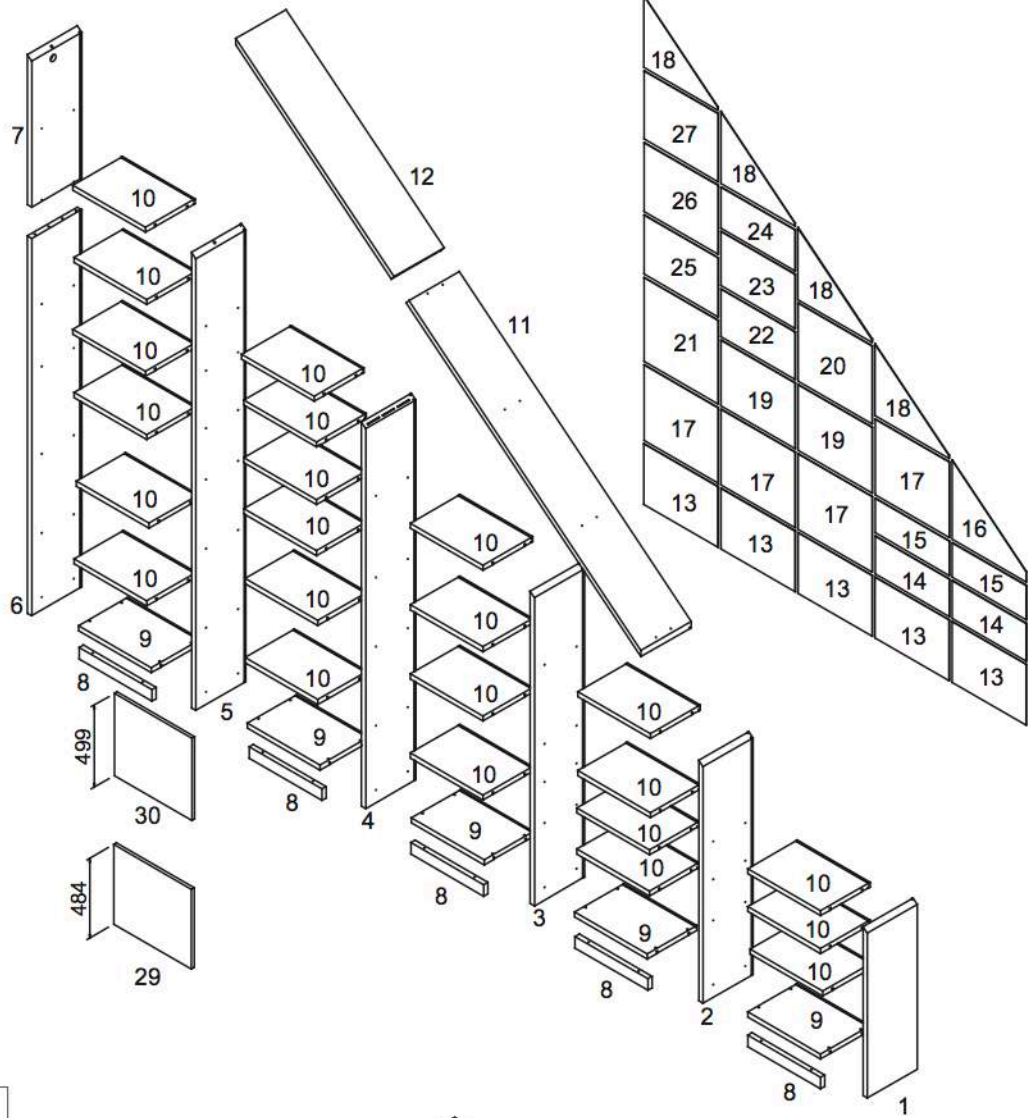

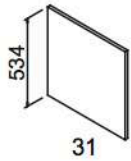
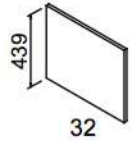
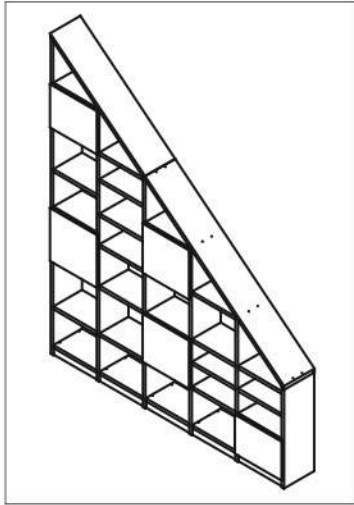

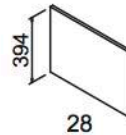

Benötigtes Werkzeug

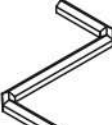

LISTE DER MONTAGETEILE

 A x112	 Bx18	 C x1	 J x10	 L x10	 Fx2	 Gx2	 Hx2
 D x12	 Ex38	 Mx5	 Nx5	 Px12	 Rx20		

1

 Bx10	 C x1	 A x112
 felt washer D x12	 Fx1	

WICHTIG !!!
Stecken Sie die
Schraube vor
der
Montage hinein

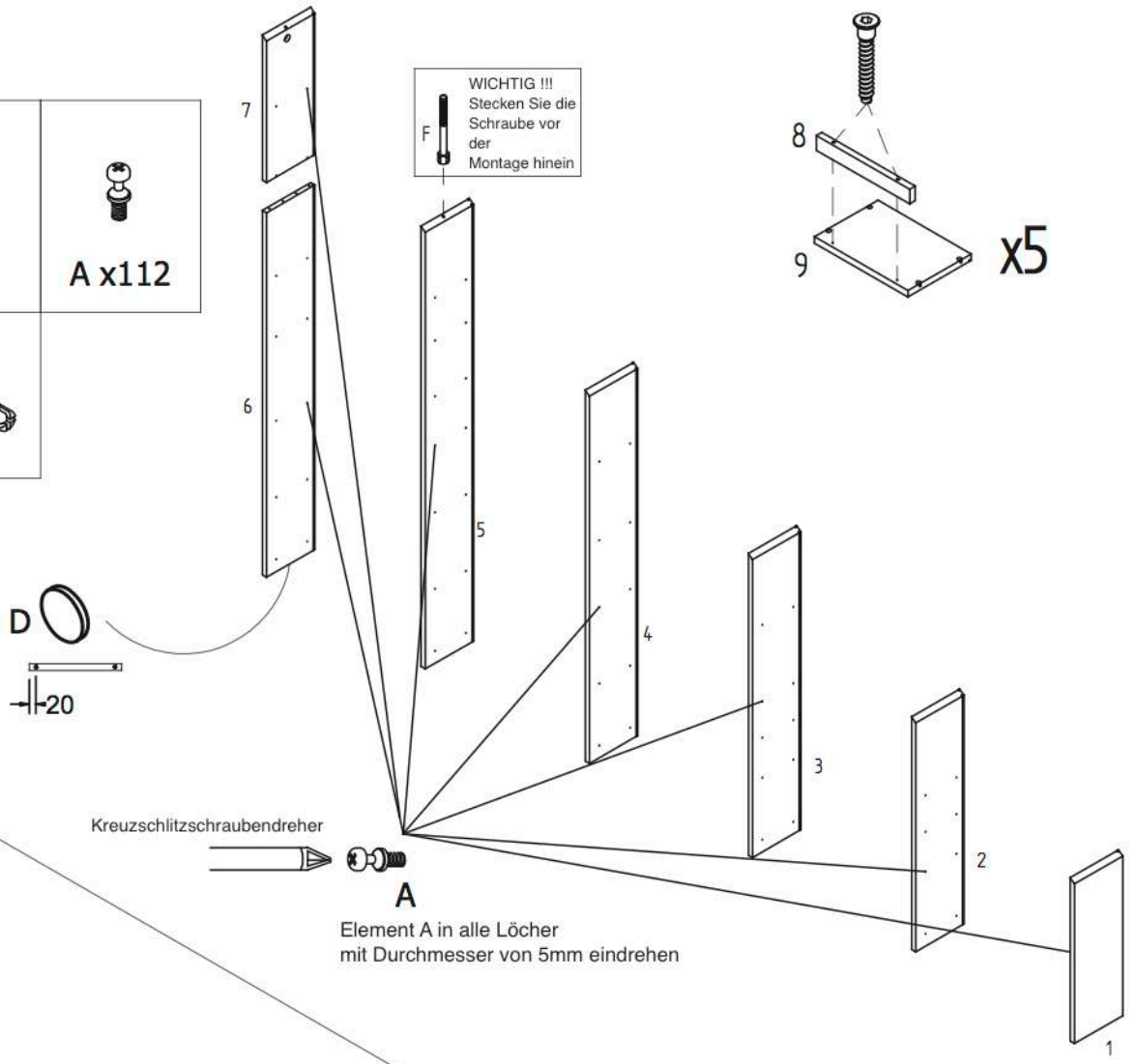
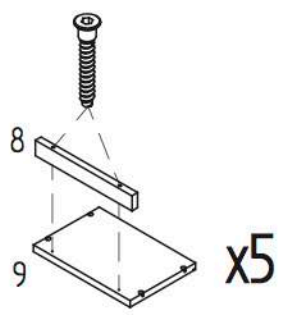

2

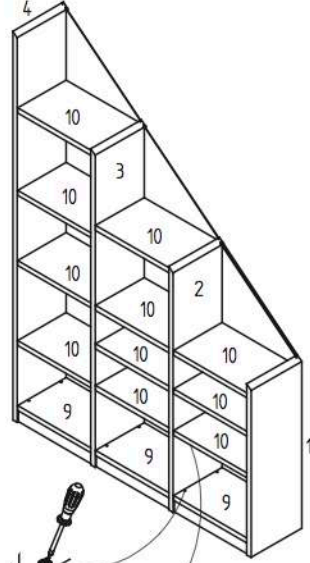
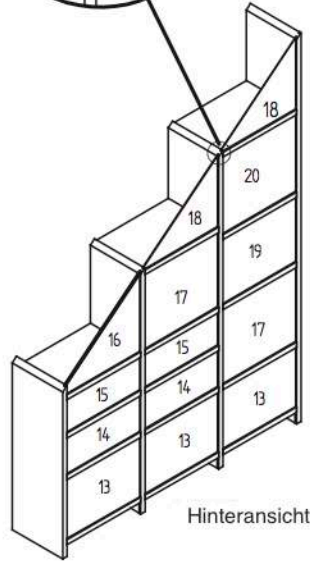
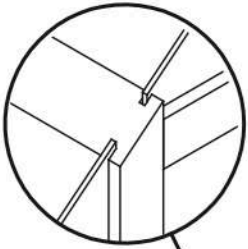

Kreuzschlitzschraubendreher

A
Element A in alle Löcher
mit Durchmesser von 5mm eindrehen

3

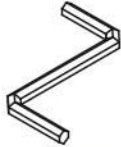
 B x8
 C x1

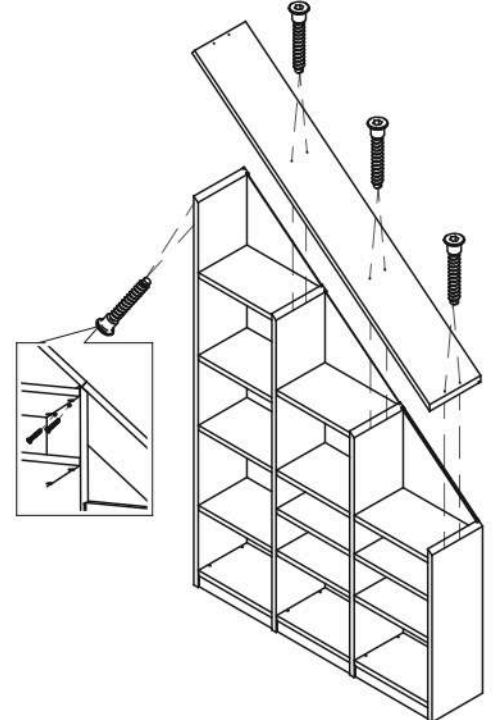

4



Fx1

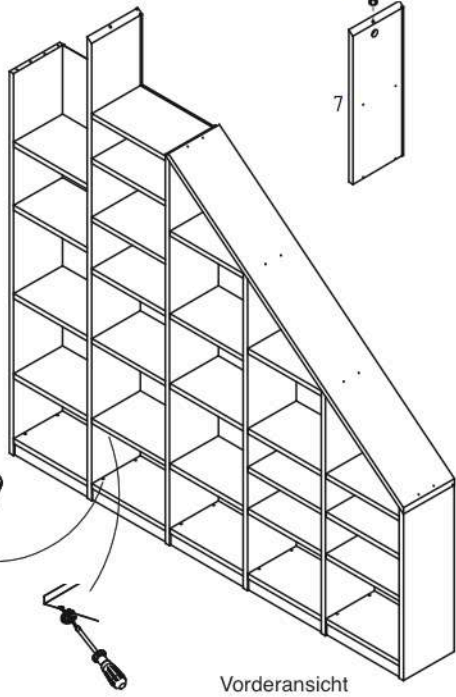
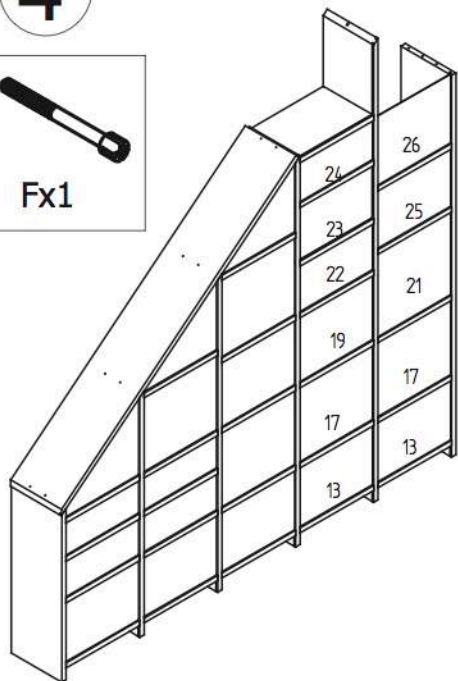

Vorderansicht

WICHTIG !!!
Stecken Sie die Schraube
vor der Montage hinein

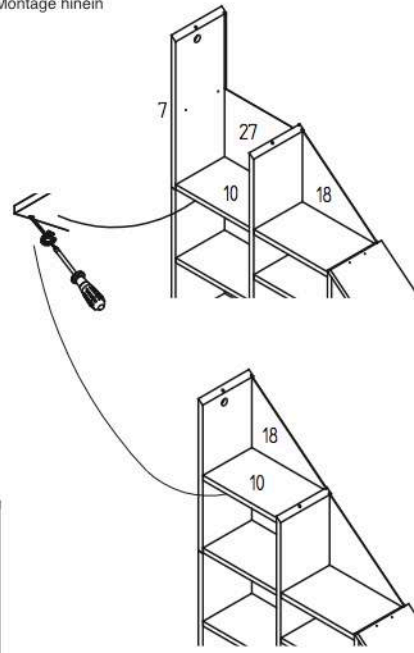

5

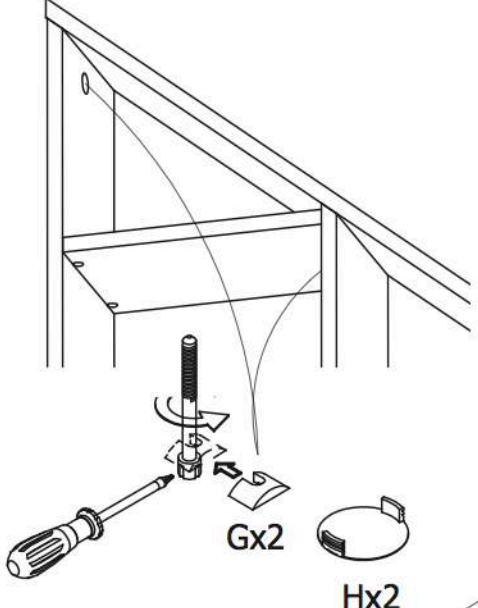
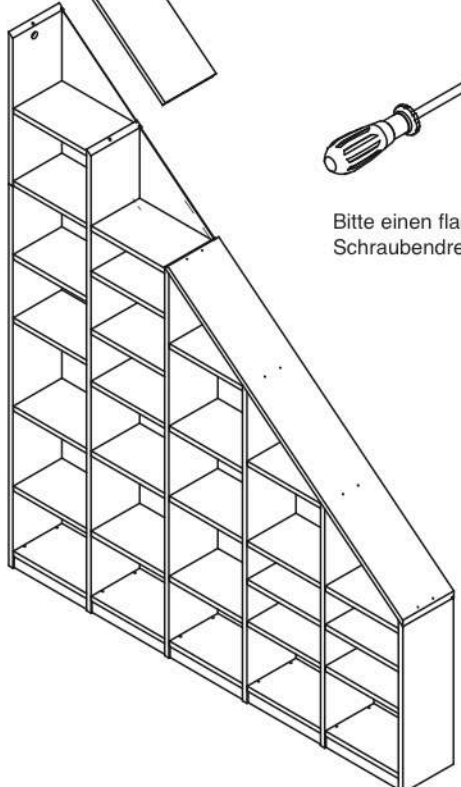
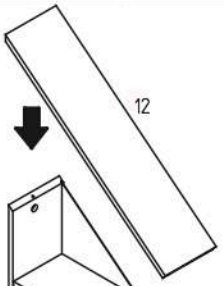
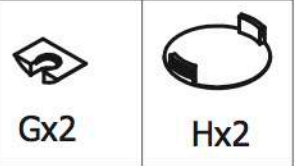

Bitte einen flachen
Schraubendreher benutzen.

6

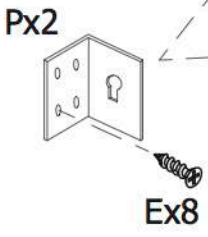

SEHR WICHTIG !!!
Bitte das Möbelstück unbedingt an die Wand festschrauben.
Benutzen Sie dabei Schrauben und Dübel die für Ihre Wand vorgeschrieben sind.

7

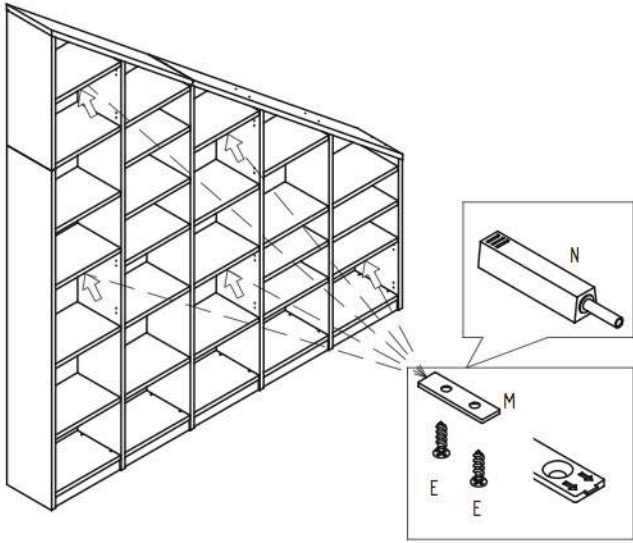
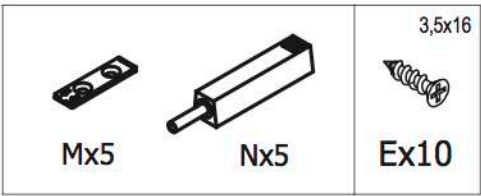

8

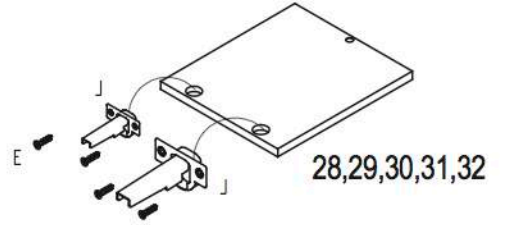
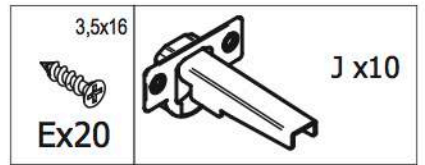

9

